

"Quick-Pitch" Diaphragm

The new *Quick-Pitch Diaphragm* by N.A. Woodworth is designed specifically to provide quick and accurate part changeovers in a simple and economical manner. Aimed primarily at gear families, the chuck also has applications in hard turning and grinding operations where repeatability, inter-changeability and roundness are a concern.

The key to the design is the simplicity of the quick-change system. A fixed length pin locates against the master jaw of the diaphragm and extends the

distance to the pitch diameter. The pin is housed in a jaw that orients the unit and contains the "Quick-Change" feature of a snap in place housing and retained screw system. Replacement of worn pin sets is as simple as sliding out the old and inserting the new, no adjustment is necessary.

Four models are available spanning pitch diameters from 25 mm to 350 mm with three and six jaw systems.

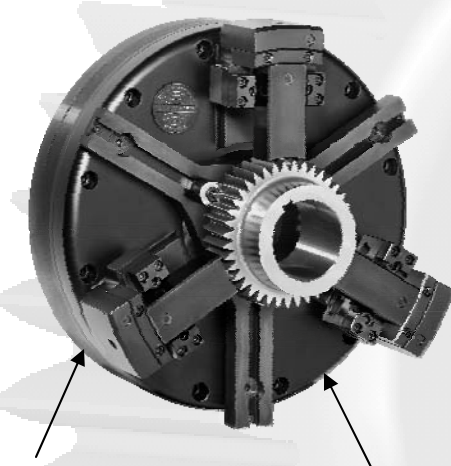

Sealed Design

N.A. Woodworth Original Radius Diaphragm

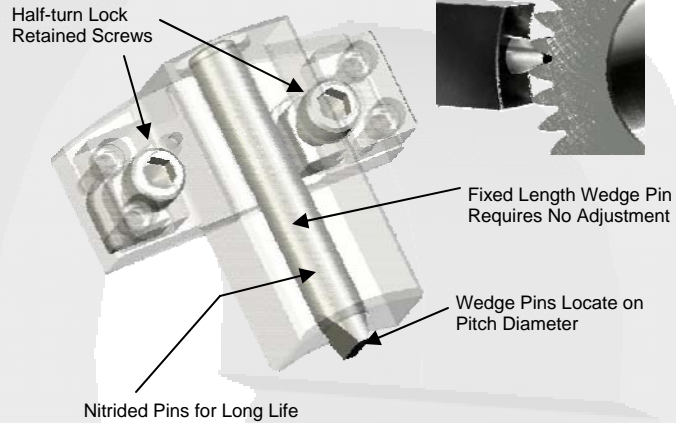

Chuck Sizing for Part Ranges:

Model Name	No. of Jaws	Chuck Diameter	Major Diameter Range Min./Max.
PLD - 180	3	178mm	25mm - 100mm
PLD - 250	3	250mm	100mm - 170mm
PLD - 345	3	345mm	170mm - 245mm
PLD - 450	6	450mm	245mm - 350mm

FEATURES:

- Jaw change in 60 seconds
- Accommodates any number of gear teeth
- Compliance for tooth space variation
- Optional synchronizing pins for auto-load
- Standard "pull-back" action
- Centrifugal force compensation for higher speeds
- Minimal maintenance, no sliding parts
- Light weight assembly

IDEAL FOR:

- Gear families including; Sun, Ring, Pinion and Output Gears
- Spur and Helical Gears
- Hard Turning
- Grinding Applications: Face and Boring

ITW Workholding Group

Workholding Solutions
Worldwide



FORKARDT
AN ITW WORKHOLDING COMPANY



Buck Chuck
An ITW Workholding Company

W O R K H O L D I N G W O R L D W I D E L O C A T I O N S

FORKARDT DEUTSCHLAND GMBH
Heinrich-Hertz-Str. 7
D-40699 Erkrath
Tel: (+49) 211-25 06-0
Fax: (+49) 211-25 06-221
E-Mail: info@forkardt.com

FORKARDT SCHWEIZ AG
Industriestrasse 3
CH-8307 Effretikon
Tel: (+41) 52-3 5531 31
Fax: (+41) 52-3 4352 40
E-Mail: info-ch@forkardt.com

FORKARDT FRANCE S.A.R.L.
28 Avenue de Bobigny
F-93135 Noisy le Sec Cédex
Tel: (+33) 1-41 83 12 40
Fax: (+33) 1-48 40 47 59
E-Mail: forkardt.france@forkardt.com

BUCK CHUCK
2155 Traversefield Drive
Traverse City, MI 49686, USA
Tel: (+1) 231-995-8312
Fax: (+1) 231-947-4953
E-Mail: buck.forkardt@forkardt.com

N.A. WOODWORTH
2002 Stephenson Hwy.
Troy, MI 48083, USA
Toll Free: 800.544.3823
E-Mail: sales@itworkholding.com
Website: www.itworkholding.com

www.forkardt.com

www.itworkholding.com